

830nm Polarization Maintaining Optical Isolator



Key Features

- High Isolation
- Low Insertion Loss
- High Extinction Ratio
- High Stability and Reliability
- Cost Effective

Applications

- Fiber optic Amplifiers
- Pump Laser Source
- Fiber optic Sensor
- Test and Measurement
- Instrumentation

Performance Specifications

Parameter	Specifications
Operation Wavelength	820nm to 840nm
Typical Peak Isolation	25dB
Minimum Isolation	20dB
Typical Insertion Loss	0.8dB
Maximum Insertion Loss	1.2dB
Extinction Ratio	20dB(Typ. 25dB)
PMD	0.2ps
Return Loss	≥ 50dB
Optical Power	600mW
Operating Temperature	0 to + 65°C
Storage Temperature	-40 to + 85°C
Fiber Type	See Order Information
Package Dimensions	L52mm x W28mm x H27mm

Note:

1. The PM fiber and the connector key are aligned to the slow axis.
2. The ER is for fiber ≤ 0.75 meter. Increase fiber length can decrease the ER.
3. For devices with connectors, insertion loss will be 0.3dB higher, return loss will be 5dB lower, and extinction loss will be 2dB lower.

Mechanical Dimensions

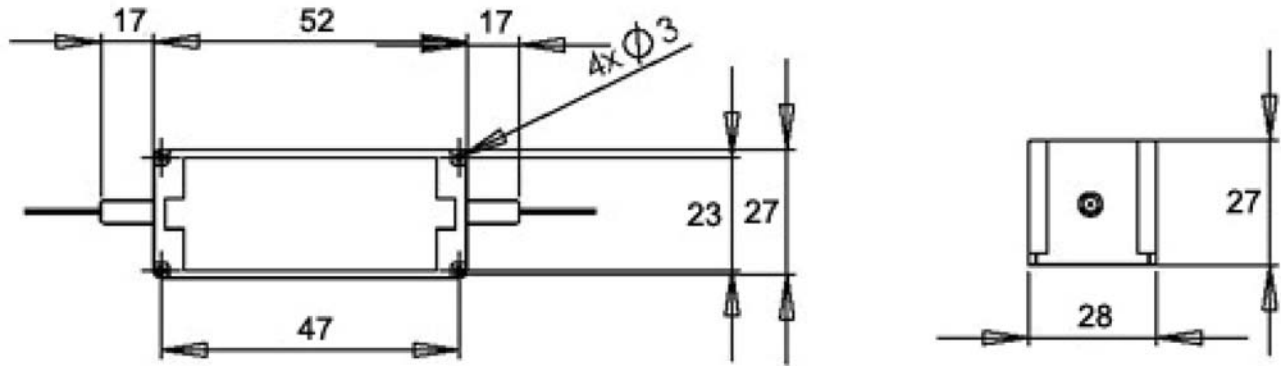

Ordering Information

PMIS	<input type="checkbox"/> <input type="checkbox"/>	<input type="checkbox"/>	<input type="checkbox"/>	<input type="checkbox"/>	<input type="checkbox"/>	<input type="checkbox"/> <input type="checkbox"/>	<input type="checkbox"/>
	Wavelength	Grade	Pigtail Style	Fiber Length	Fiber Type	In/Out Connector	Working axis
	83 = 830nm	P = Grade P	1 = Bare Fiber 2 = 900um Jacket	1 = 0.25m 2 = 0.5m 3 = 1.0m 4 = Custom Length	1 = PM850 S = Special	0 = None 1 = FC/APC 2 = FC/PC 3 = SC/APC 4 = SC/PC 5 = ST 6 = LC/UPC 7 = LC/APC X=Special	S = Slow axis working B = Both axes working F = Fast axis working

Product specifications and descriptions in this document subject to change without notice.

© AC Photonics, Inc.